

**POWER PLANT - ADJUSTMENT/TEST  
(PT6A-114/PT6A-114A)**

**1. General**

- A. This adjustment/test procedure outlines individual procedures to guide maintenance personnel for operating and adjusting a PT6A-114/PT6A-114A engine. Procedures described are not necessarily in maintenance sequence; select an individual or group of procedures to meet the maintenance requirement.
- B. For engine power lever and control rigging, refer to Chapter 76, Engine Control Rigging - Adjustment/Test.

**2. Engine Operating Limits**

- A. The following limitations shall be observed during testing. If at any time the limits are exceeded, immediately shut down the engine by placing the throttle at flight idle and the fuel condition lever in cutoff.
  - (1) For limits during engine adjustment and testing, refer to Figure 501, Engine Operating Limits, and Table 501 and Table 502.

**Table 501. PT6A-114 Engine Operating Limits**

| POWER SETTING          | TORQUE FOOT-POUNDS (8) | MAXIMUM ITT °C | GAS GENERATOR RPM % N <sub>g</sub> (1) (9) | PROPELLER RPM | OIL PRESSURE PSIG (2) | OIL TEMP °C (5) | SHAFT HORSE-POWER (7) |
|------------------------|------------------------|----------------|--------------------------------------------|---------------|-----------------------|-----------------|-----------------------|
| Takeoff                | 1980                   | 805            | 101.6                                      | 1900          | 85 to 105             | 10 to 99        | 600                   |
| Maximum Climb          | 1980                   | 765            | 101.6                                      | 1900          | 85 to 105             | 0 to 99         | 600                   |
| Maximum Cruise         | 1980                   | 740            | 101.6                                      | 1900          | 85 to 105             | 0 to 99         | 600                   |
| Idle                   |                        | 685            | 52 to 54 (Minimum)                         |               | 40 (minimum)          | -40 to 99       |                       |
| Maximum Reverse (3)    | 1980                   | 805            | 101.6                                      | 1825          | 85 to 105             | 0 to 99         | 600                   |
| Transient              | 2400 (10)              | 900 (4)        | 102.6 (4)                                  | 2090 (11)     | 85 to 105             | 104 (12)        |                       |
| Starting               |                        | 1090 (4) (13)  |                                            |               |                       | -40 (minimum)   |                       |
| Maximum Continuous (6) | 1980                   | 805            | 101.6                                      | 1900          | 85 to 105             | 10 to 99        | 600                   |

- 1. For every 10°C (18°F) below -30°C (-22°F) ambient temperature, reduce maximum allowable N<sub>g</sub> by 2.2%.
- 2. Normal oil pressure is 85 to 105 PSI at gas generator speeds above 72% with oil temperature between 60°C and 70°C (140°F and 185°F). Oil pressure below 85 PSI is undesirable and should be tolerated only for completion of the flight, preferably at a reduced power setting. Oil pressure below normal should be reported as an engine discrepancy and should be corrected before the next takeoff. Oil pressures below 40 PSI are unsafe and require that either the engine be shut down or a landing be made as soon as possible using the minimum power required to sustain flight. Minimum oil pressure above 27,000 N<sub>g</sub> is 85 PSI.
- 3. Reverse power operation is limited to one minute.
- 4. These values are time limited to five seconds.
- 5. For increased oil service life, an oil temperature below 80°C (176°F) is recommended. A minimum oil temperature of 55°C (130°F) is recommended for fuel heater operation at takeoff power.
- 6. Use of this rating is intended for abnormal situations (i.e., maintain altitude or climb out of extreme icing or windshear conditions).
- 7. The maximum allowable SHP is 600. Less than 600 SHP is available under certain temperature and altitude conditions as reflected in the takeoff, climb and cruise performance charts.
- 8. If maximum torque is used, set N<sub>p</sub> so as to not exceed power limitations.
- 9. 100% N<sub>g</sub> is 37,500 RPM.

10. These values are limited to 20 seconds.
11. If propeller governor fails toward overspeed, permissible to complete a flight with propeller control via overspeed governor (on engines so equipped) provided this limit is not exceeded.
12. Maximum permissible transient oil temperature is 104°C (219°F) for 10 minutes.
13. Investigate starting temperatures above 850°C (1562°F) for cause.

**Table 502. PT6A-114A Engine Operating Limits**

| POWER SETTING          | TORQUE FOOT-POUNDS (8) | MAXIMUM ITT °C | GAS GENERATOR RPM % N <sub>g</sub> (1) (9) | PROPELLER RPM | OIL PRESSURE PSIG (2) | OIL TEMP °C (5) | SHAFT HORSE-POWER (7) |
|------------------------|------------------------|----------------|--------------------------------------------|---------------|-----------------------|-----------------|-----------------------|
| Takeoff                | 1980                   | 805            | 101.6                                      | 1900          | 85 to 105             | 10 to 99        | 675                   |
| Maximum Climb          | 1980                   | 765            | 101.6                                      | 1900          | 85 to 105             | 0 to 99         | 675                   |
| Maximum Cruise         | 1980                   | 740            | 101.6                                      | 1900          | 85 to 105             | 0 to 99         | 675                   |
| Idle                   |                        | 685            | 52 to 54 (Minimum)                         |               | 40 (minimum)          | -40 to 99       |                       |
| Maximum Reverse (3)    | 1980                   | 805            | 101.6                                      | 1825          | 85 to 105             | 0 to 99         | 675                   |
| Transient              | 2400 (10)              | 900 (4)        | 102.6 (4)                                  | 2090 (11)     | 85 to 105             | 104 (12)        |                       |
| Starting               |                        | 1090 (4) (13)  |                                            |               |                       | -40 (minimum)   |                       |
| Maximum Continuous (6) | 1980                   | 805            | 101.6                                      | 1900          | 85 to 105             | 10 to 99        | 675                   |

1. For every 10°C (18°F) below -30°C (-22°F) ambient temperature, reduce maximum allowable N<sub>g</sub> by 2.2%.
2. Normal oil pressure is 85 to 105 PSI at gas generator speeds above 72% with oil temperature between 60°C and 70°C (140°F and 185°F). Oil pressure below 85 PSI is undesirable and should be tolerated only for completion of the flight, preferably at a reduced power setting. Oil pressure below normal should be reported as an engine discrepancy and should be corrected before the next takeoff. Oil pressures below 40 PSI are unsafe and require that either the engine be shut down or a landing be made as soon as possible using the minimum power required to sustain flight. Minimum oil pressure above 27,000 N<sub>g</sub> is 85 PSI.
3. Reverse power operation is limited to one minute.
4. These values are time limited to five seconds.
5. For increased oil service life, an oil temperature below 80°C (176°F) is recommended. A minimum oil temperature of 55°C (130°F) is recommended for fuel heater operation at takeoff power.
6. Use of this rating is intended for abnormal situations (i.e., maintain altitude or climb out of extreme icing or windshear conditions).
7. The maximum allowable SHP is 675. Less than 675 SHP is available under certain temperature and altitude conditions as reflected in the takeoff, climb and cruise performance charts.
8. If maximum torque is used, set N<sub>p</sub> so as to not exceed power limitations.
9. 100% N<sub>g</sub> is 37,500 RPM.
10. These valves are limited to 20 seconds.
11. If propeller governor fails toward overspeed, permissible to complete a flight with propeller control via overspeed governor (on engines so equipped) provided this limit is not exceeded.
12. Maximum permissible transient oil temperature is 104°C (219°F) for 10 minutes.
13. Investigate starting temperatures above 850°C (1562°F) for cause.

### 3. 600 SHP Engine (PT6A-114) Acceleration Check

#### A. Acceleration Check (Refer to Figure 502).

- (1) Before any adjustments are made to the acceleration adjuster dome. Mark acceleration dome and fuel control unit

with a marker pen to establish an initial reference point.

- (2) Start engine in accordance with Pilot's Operating Handbook and FAA Approved Airplane Flight Manual. Operate engine at idle for five minutes to allow temperatures to stabilize.
- (3) Slowly advance power lever to obtain take off power (1900 RPM and 1658 foot-pounds torque). Record percent  $N_g$  at takeoff power and mark power lever position on pedestal.
- (4) Reduce power to idle.
- (5) Compute 97.5 percent  $N_g$  recorded previously.
- (6) Set power lever to obtain 63 percent  $N_g$ .
- (7) Move power lever rapidly from 63 percent  $N_g$  to position marked on pedestal cover for takeoff power, and record time to obtain 97.5 percent takeoff  $N_g$  as previously computed. As soon as 97.5 percent of takeoff  $N_g$  is achieved, retard power lever to idle to preclude and overtorque condition.
- (8) Acceleration time should fall within limits shown in Figure 503. If not, rotate acceleration adjuster dome one click at a time until requirement is met. Rotate dome clockwise to increase acceleration rate. Do not exceed three clicks. Lockwire adjuster dome. (Refer to Figure 502.)

#### 4. 675 SHP Engine (PT6A-114A) Acceleration Check

##### A. Acceleration Check (Refer to Figure 502 and Figure 503).

- (1) Before any adjustments are made to the acceleration adjuster dome. Mark acceleration dome and fuel control unit with a marker pen to establish an initial reference point.
- (2) Start engine in accordance with Pilot's Operating Handbook and FAA Approved Airplane Flight Manual. Operate engine at idle for five minutes to allow temperatures to stabilize.
- (3) Slowly advance power lever to obtain take off power (1900 RPM and 1865 foot-pounds torque). Record percent  $N_g$  at takeoff power and mark power lever position on pedestal.
- (4) Reduce power to idle.
- (5) Compute 97.5 percent  $N_g$  recorded in step (2).
- (6) Set power lever to obtain 63 percent  $N_g$ .
- (7) Move power lever rapidly from 63 percent  $N_g$  to position marked on pedestal cover for takeoff power, and record time to obtain 97.5 percent takeoff  $N_g$  as previously computed. As soon as 97.5 percent of takeoff  $N_g$  is achieved, retard power lever to idle to preclude an overtorque condition.
- (8) Acceleration time shall fall within limits shown in Figure 503. If not, rotate acceleration adjuster dome one click at a time until requirement is met. Rotate dome clockwise to increase acceleration rate. Do not exceed three clicks. Lockwire adjuster dome.

Figure 501 : Sheet 1 : Engine Operating Limits

A21761

- AREA A NO ACTION REQUIRED.
- AREA B VISUAL INSPECTION AND RECORD IN THE ENGINE LOGBOOK.
- AREA C
  1. PERFORM HOT SECTION INSPECTION.
  2. RETURN COMPRESSOR TURBINE BLADE AND DISC ASSEMBLY TO AN OVERHAUL FACILITY FOR STRETCH CHECK AND FLUORESCENT PENETRANT INSPECTION.

**NOTE:** INTERTURBINE TEMPERATURES SHOWN MAKE NO ALLOWANCE FOR CORRECTION FACTORS OR INSTRUMENT ERRORS. BUT DO ALLOW FOR SOME TYPICAL INSTRUMENT LAG.

\* IF TEMPERATURE EXCEEDS THIS VALUE FOR TWO SECONDS RETURN ENGINE TO AN OVERHAUL FACILITY. COMPRESSOR TURBINE AND POWER TURBINE BLADES MUST BE DISCHARGED AND BOTH TURBINE DISCS SUBJECTED TO STRETCH CHECK AND FLUORESCENT PENETRANT INSPECTION.

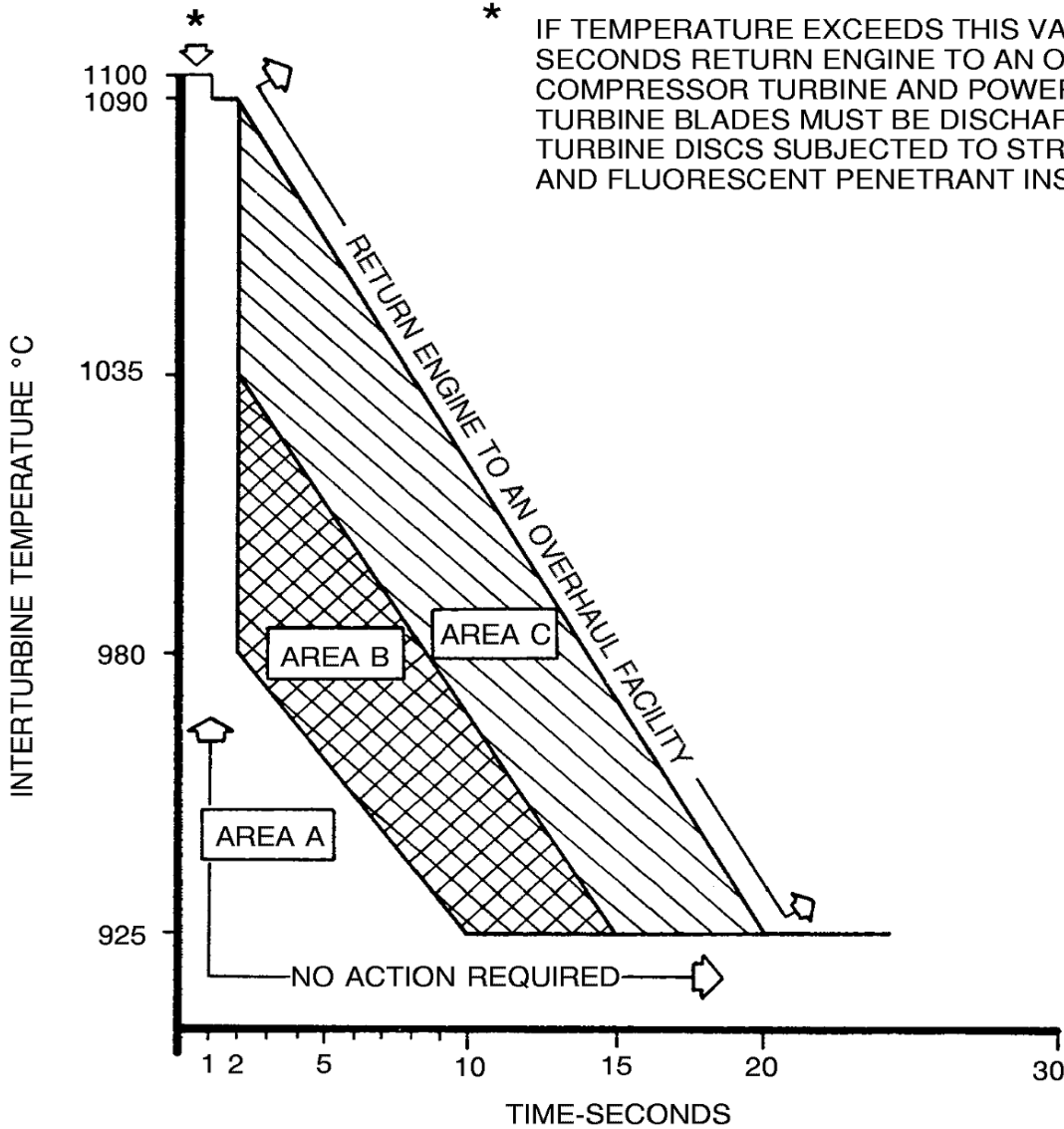

OVERTEMPERATURE LIMITS  
(STARTING CONDITIONS ONLY)  
PT6A-114 AND PT6A-114A

2693X1009

Figure 501 : Sheet 2 : Engine Operating Limits

A21762

AREA A 1. DETERMINE AND CORRECT CAUSE OF  
OVERTEMPERATURE.  
2. PERFORM VISUAL INSPECTION.  
3. RECORD IN ENGINE LOGBOOK.

AREA B PERFORM HOT SECTION INSPECTION.

AREA C 1. PERFORM HOT SECTION INSPECTION.  
2. RETURN COMPRESSOR TURBINE BLADE AND DISC  
ASSEMBLY TO AN OVERHAUL FACILITY FOR STRETCH  
CHECK AND FLUORESCENT PENETRANT INSPECTION.

\* IF TEMPERATURE EXCEEDS THIS VALUE FOR TWO  
SECONDS RETURN ENGINE TO AN OVERHAUL FACILITY.  
COMPRESSOR TURBINE AND POWER  
TURBINE BLADES MUST BE DISCHARGED AND BOTH TURBINE  
DISCS SUBJECTED TO STRETCH CHECK  
AND FLUORESCENT PENETRANT INSPECTION.

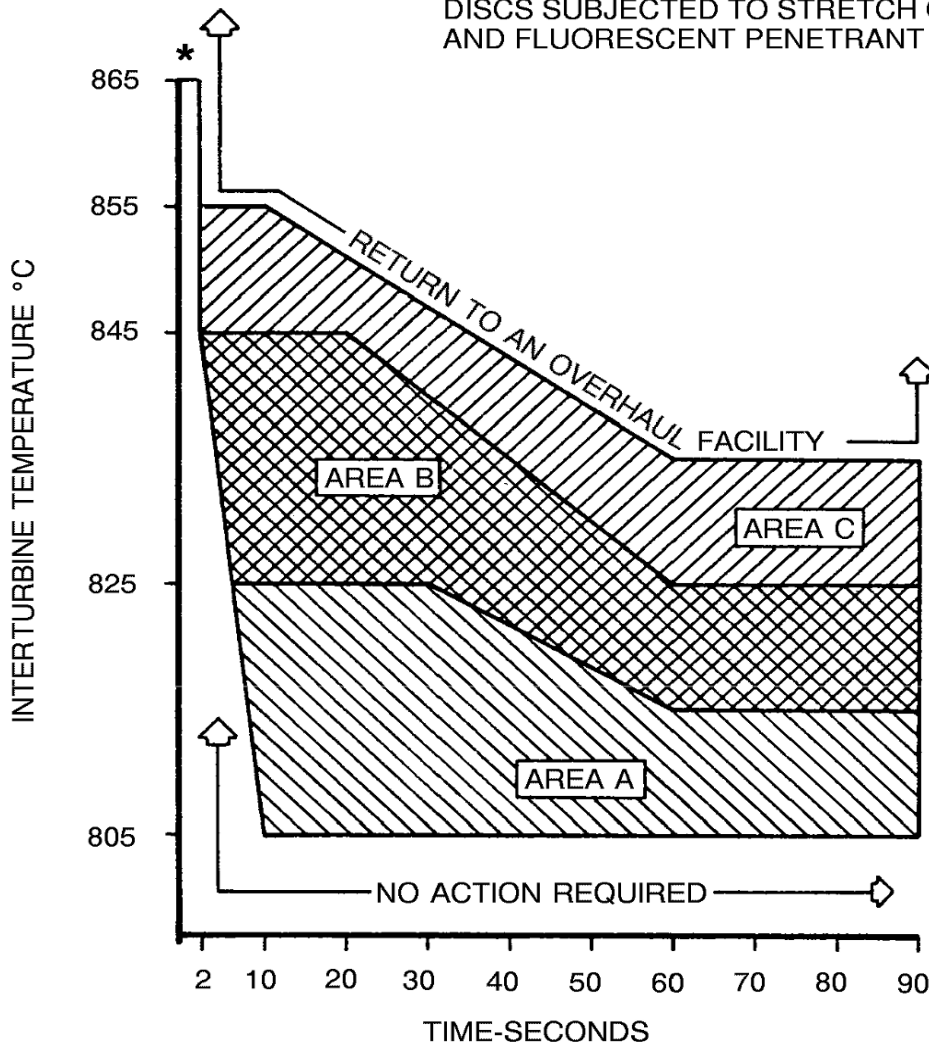

OVERTEMPERATURE LIMITS  
(ALL CONDITIONS EXCEPT STARTING)  
PT6A-114 AND PTA6A-114A

2693X1010

Figure 501 : Sheet 3 : Engine Operating Limits

A21787

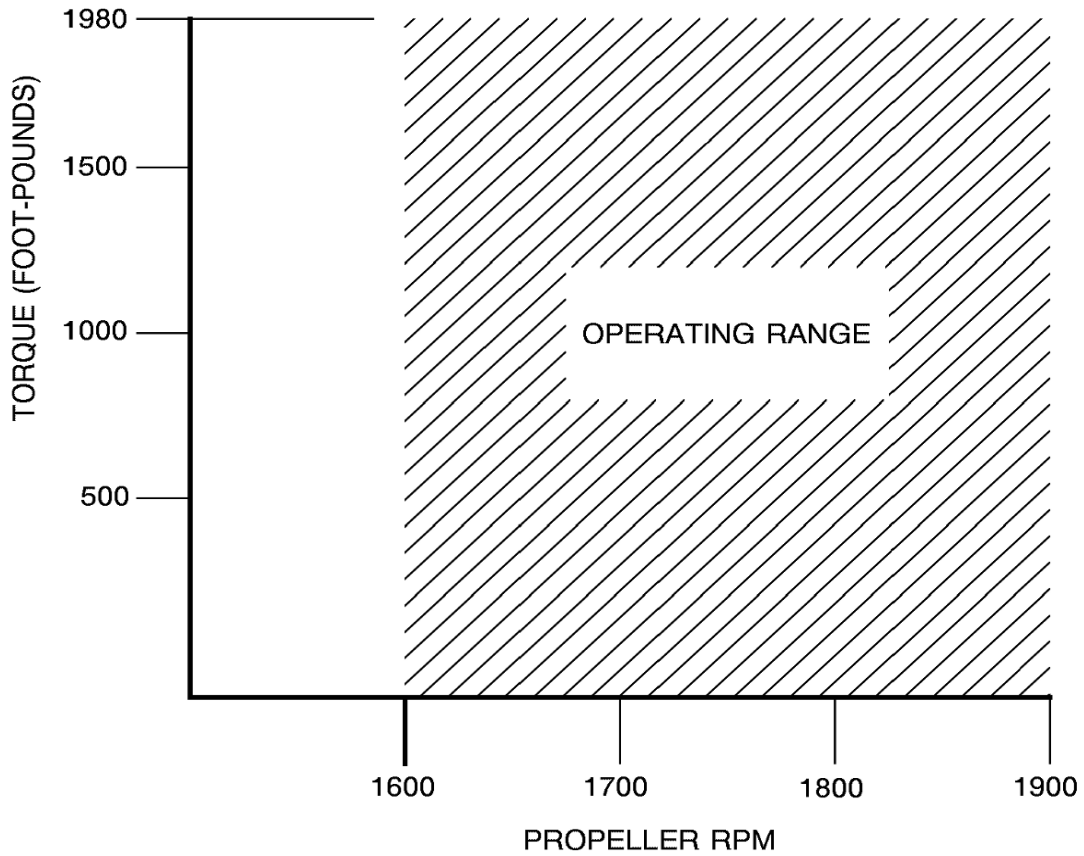

- NOTE 1:** MAXIMUM TORQUE IS 1980 FOOT-POUNDS AT 1900 RPM. IF MAXIMUM TORQUE IS USED, SET  $N_p$  SO AS NOT TO EXCEED POWER LIMITATIONS.
- NOTE 2:** REFER TO SHEET 7 FOR ACTION REQUIRED IF TORQUE LIMIT IS EXCEEDED.
- NOTE 3:** TRANSIENT TORQUE IS 2400 FOOT-POUNDS, TRANSIENT RPM IS 2090. VALUES LIMITED TO 20 SECONDS.
- NOTE 4:** MAXIMUM REVERSE TORQUE LIMIT IS 1980 FOOT-POUNDS. REVERSE OPERATION IS LIMITED TO ONE MINUTE.

PROPELLER RPM VS TORQUE

600 SHP ENGINE - PT6A-114

2693T1011

Figure 501 : Sheet 4 : Engine Operating Limits

A21788

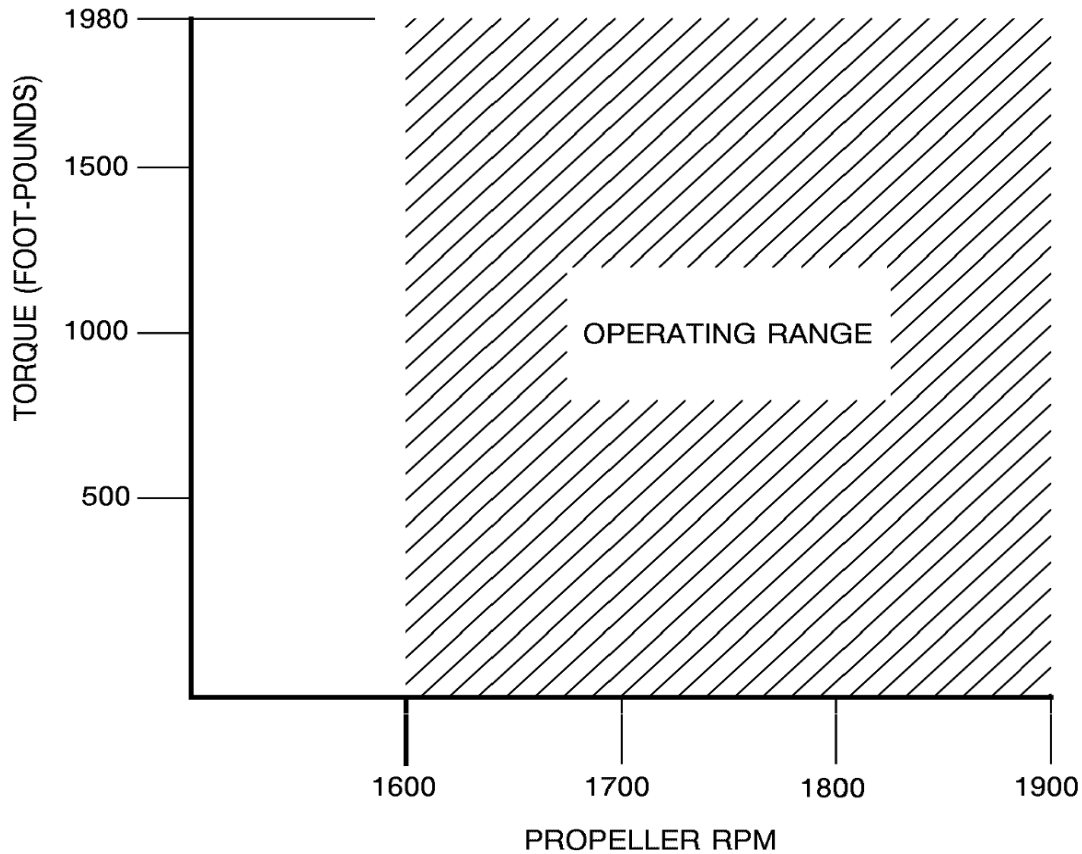

- NOTE 1:** MAXIMUM TORQUE IS 1980 FOOT-POUNDS AT 1900 RPM. IF MAXIMUM TORQUE IS USED, SET  $N_p$  SO AS NOT TO EXCEED POWER LIMITATIONS.
- NOTE 2:** REFER TO SHEET 7 FOR ACTION REQUIRED IF TORQUE LIMIT IS EXCEEDED.
- NOTE 3:** TRANSIENT TORQUE IS 2400 FOOT-POUNDS, TRANSIENT RPM IS 2090. VALUES LIMITED TO 20 SECONDS.
- NOTE 4:** MAXIMUM REVERSE TORQUE LIMIT IS 1980 FOOT-POUNDS. REVERSE OPERATION IS LIMITED TO ONE MINUTE.

PROPELLER RPM VS TORQUE

675 SHP ENGINE - PT6A-114A

2693T1011

Figure 501 : Sheet 5 : Engine Operating Limits

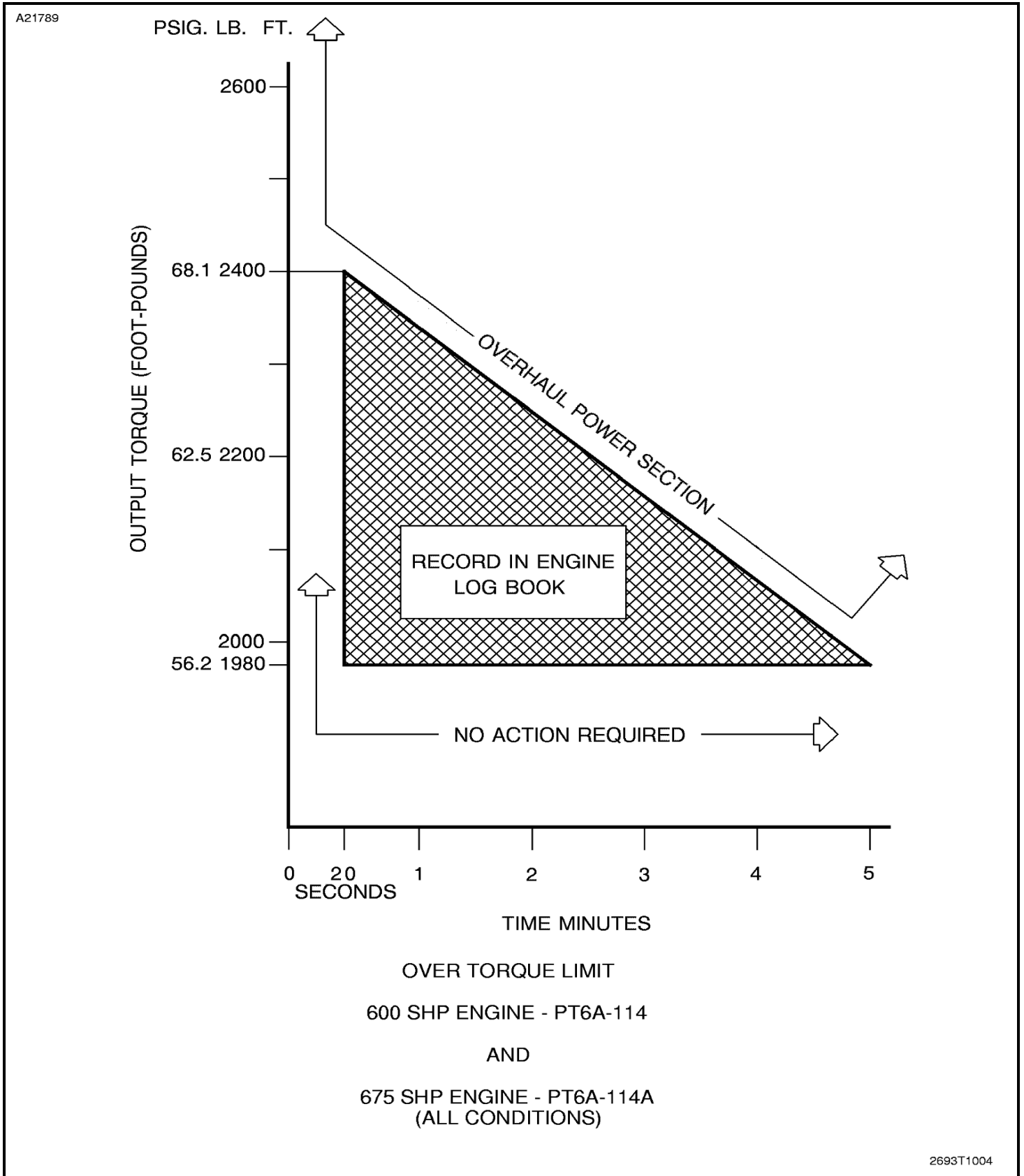
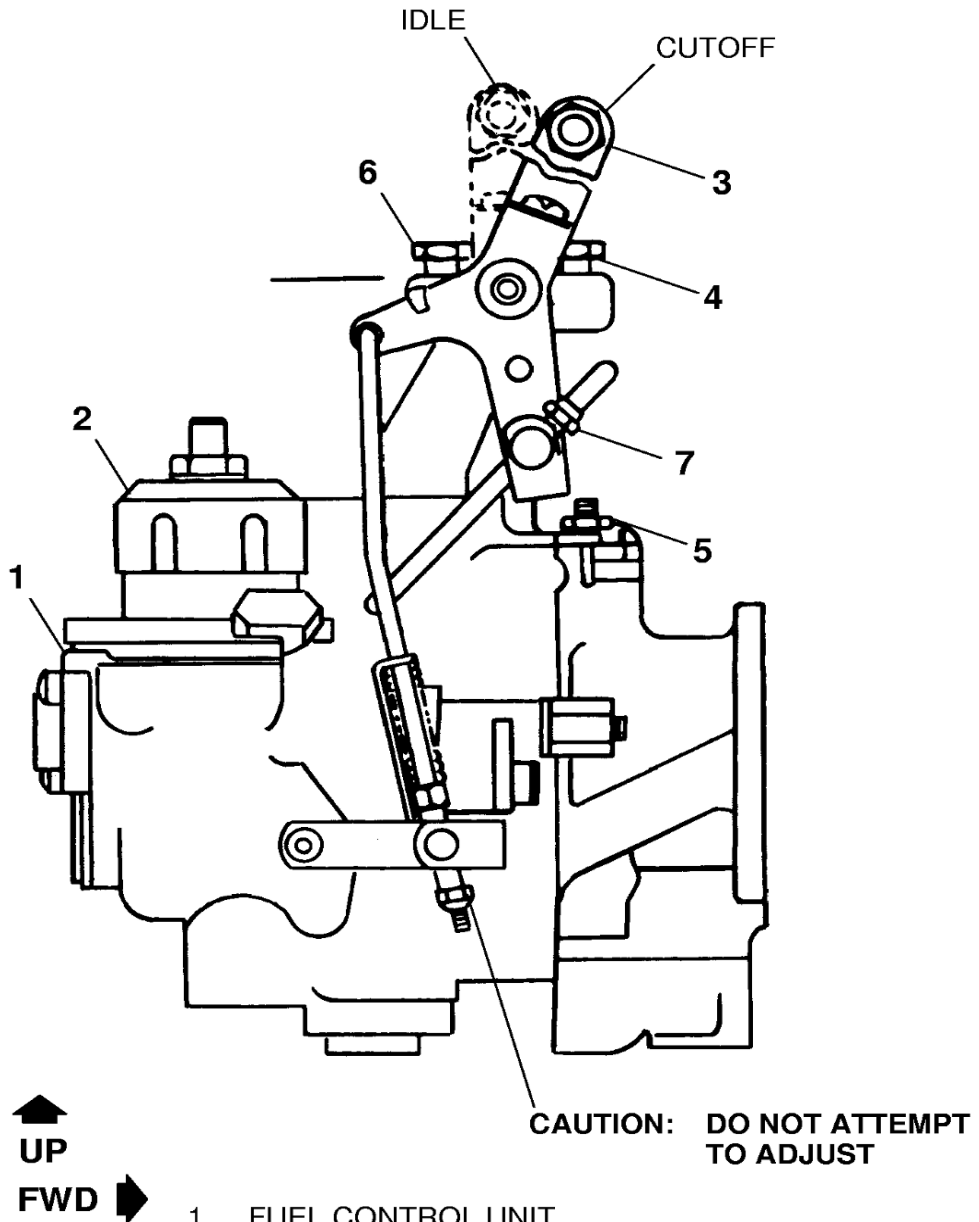



Figure 502 : Sheet 1 : Fuel Control Linkage

A21733



1. FUEL CONTROL UNIT
2. ACCELERATION DOME
3. CUTOFF LEVER
4. FUEL CUTOFF STOP BOLT
5. IDLE ADJUSTING NUT
6. HIGH IDLE STOP BOLT
7. UPPER CUTOFF AND FLIGHT IDLE LINKAGE NUT

26151026

Figure 503 : Sheet 1 : Engine Acceleration Time Versus Temperature Chart

A21767

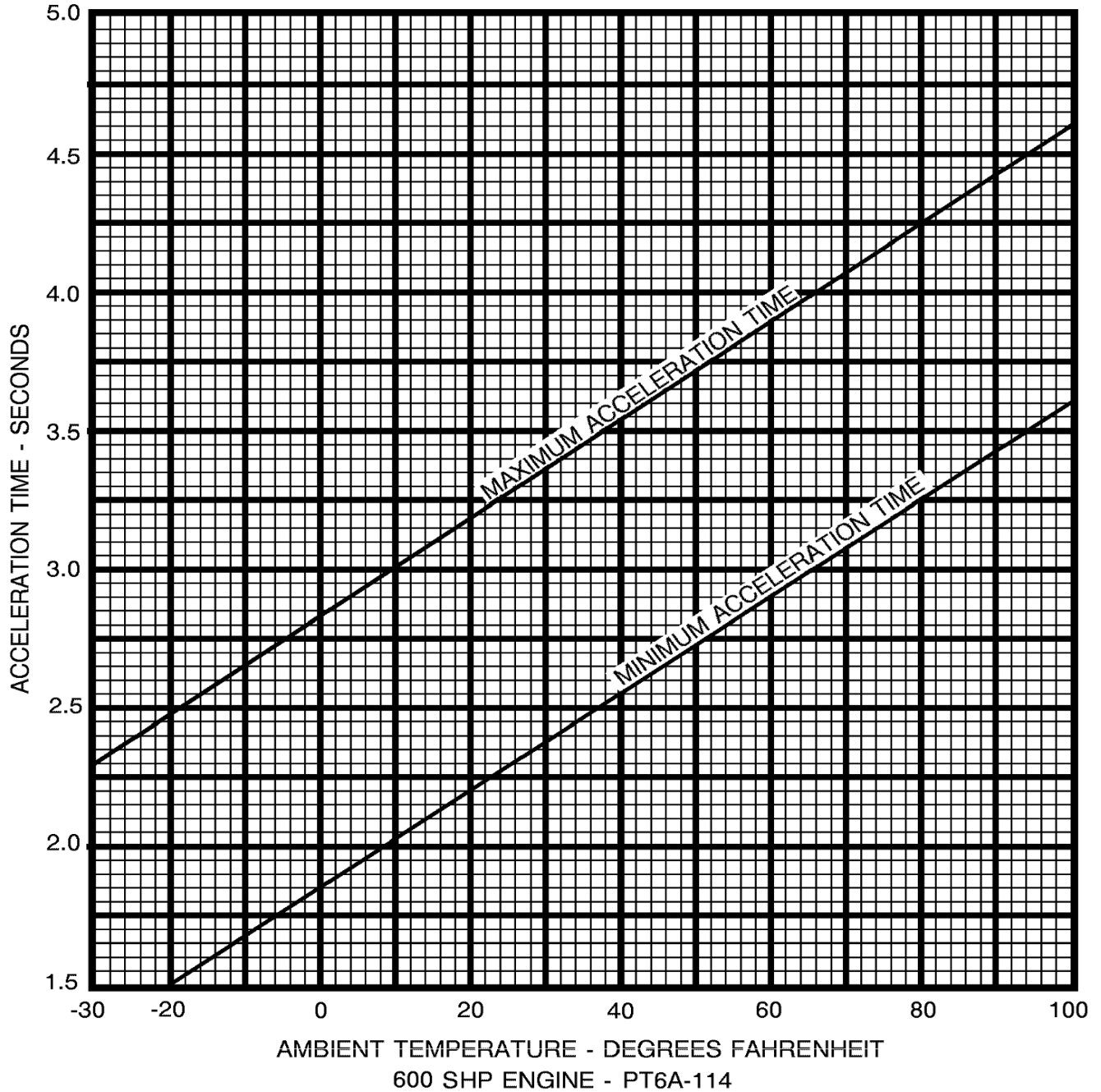

2693T1008

Figure 503 : Sheet 2 : Engine Acceleration Time Versus Temperature Chart

A21768

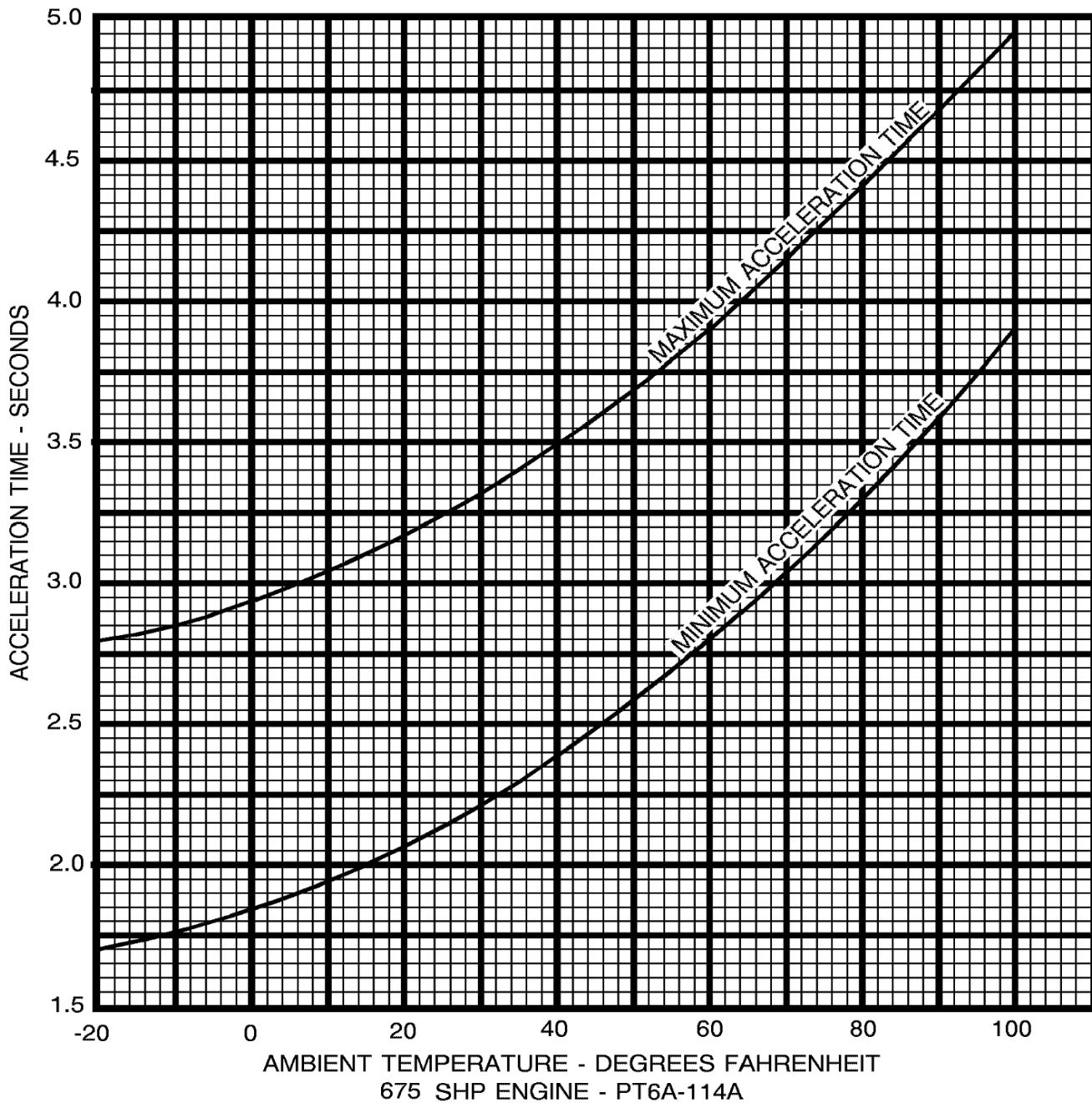

2693T1005